

## FLOW IN OPEN CHANNELS (UNIFORM FLOW)

### GEOMETRICAL PROPERTIES OF CHANNEL SECTION

The geometrical properties of a channel section can be defined by the shape of the section and the depth of flow.

1. Depth of flow,  $y$ : It is the vertical distance of the lowest point of a channel section from the free surface of water.
2. Top width,  $T$ : It is the width of the channel section at the free surface of water.
3. Wetted area,  $A$ : It is the cross-sectional area of the flow of the channel section.
4. Wetted perimeter,  $P$ : It is the length of the channel boundary in contact with the flowing water at any section.
5. Hydraulic radius,  $R$  (or Hydraulic mean depth): It is the ratio of wetted area,  $A$  and wetted perimeter,  $P$ .

$$R = \frac{A}{P}$$

6. Hydraulic depth,  $D$ : It is the ratio of wetted area,  $A$  and the top width,  $T$

$$D = \frac{A}{T}$$

7. Section factor,  $Z$ , for critical flow computation: It is the product of wetted area and the square root of the hydraulic depth,  $D$

$$Z = A\sqrt{D} = A\sqrt{\frac{A}{T}} = \frac{A^{3/2}}{T^{1/2}} = \left(\frac{A^3}{T}\right)^{1/2}$$

8. Section factor,  $Z$ , for uniform flow computation: It is the product of the wetted area and the hydraulic radius raised to the two-thirds power.

$$Z = AR^{2/3}$$

## VELOCITY DISTRIBUTION IN A CHANNEL SECTION

The velocity of flow at any channel section is not uniformly distributed. Why? This is due to the presence of free surface and the frictional resistance offered to free flow of water by the boundary of the channel.

The velocity distribution in a channel section can be measured either by a pitot tube or a currentmeter. The typical patterns of velocity distribution in rectangular, trapezoidal, triangular and circular channel sections are represented in Figure 1 below. The pattern of velocity distribution in a channel section is represented by lines of equal velocity. For typical velocity distribution curve along a vertical line of a channel section, refer to a standard text book/reference on Fluid Mechanics/Hydraulics/Open Channel Flow. In a straight reach of a channel, the maximum velocity generally occurs at a distance of 0.05 to 0.15 depth of flow from the free surface of flow. The velocity distribution in a channel section depends upon various factors such as the shape of the section, roughness of the boundary of the channel and the alignment of the channel.

The average velocity of flow in a channel section can be computed from the vertical velocity distribution curve obtained for that section from actual measurements. From measurements, it is observed that the velocity measured at 0.6 depth of flow from the free surface is near to the average velocity of flow in the vertical section. A still better approximation for the average velocity of flow can be obtained by taking the average of velocities measured at 0.2 depth of flow and 0.8 depth of flow measured from the free surface.

As the velocity distribution in a channel section is non-uniform, correction factors have to be applied while computing the kinetic energy and momentum. The kinetic energy correction factor, also called Coriolis coefficient, is denoted by the Greek symbol  $\alpha$ . The momentum correction factor, also called Boussinesq coefficient, is denoted by the Greek symbol  $\beta$ . The values of  $\alpha$  and  $\beta$  can be obtained from the actual velocity distribution profile for a channel section. From experiments, it is found that the value of kinetic energy correction factor  $\alpha$  varies from 1.03 to 1.36 for turbulent flow in fairly straight prismatic channels. Similarly, it is found from experiments that the value of momentum correction factor

$\beta$  varies from 1.01 to 1.12 for fairly straight prismatic channels. However, for the sake of simplicity, the values of  $\alpha$  and  $\beta$  are assumed to be unity in the present analysis.

## UNIFORM FLOW IN OPEN CHANNELS

When water flows in an open channel, it experiences resistance offered by the boundary of the channel. This causes loss of energy of the flowing water in the direction of flow. This resistance is overcome by the flowing water by the components of gravity forces acting on the body of water in the direction of flow.

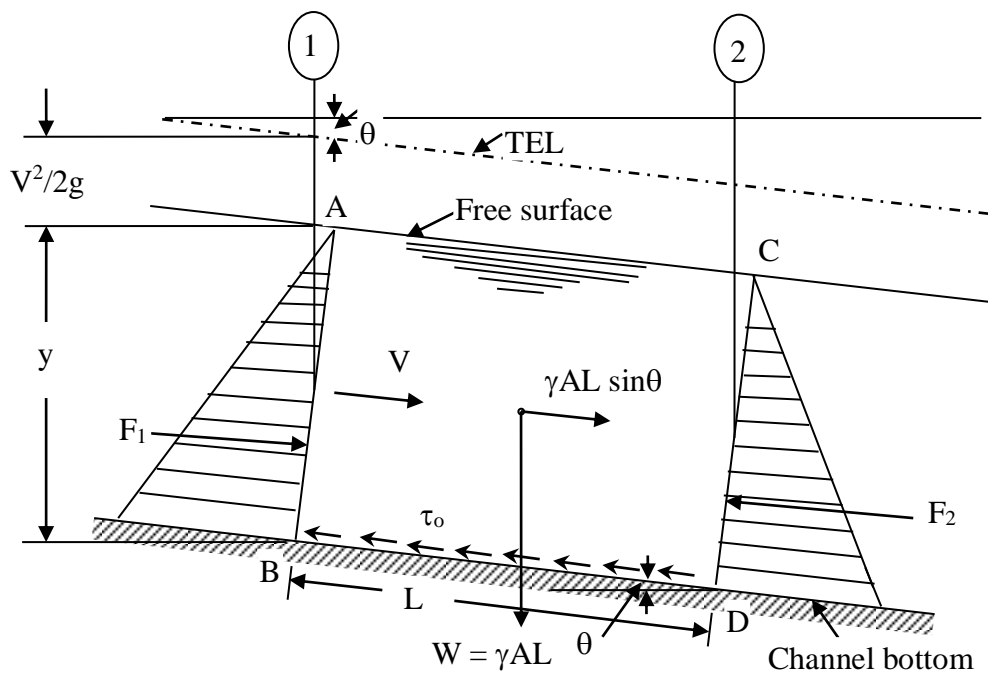

**Problem :** An open channel is V – shaped with each side being inclined at  $45^\circ$  to the vertical. If it carries a discharge of  $0.04 \text{ m}^3/\text{s}$ , when the depth of flow at the centre is  $225 \text{ mm}$ , calculate the slope of the channel assuming that Chezy's  $C = 50$ .

**Solution.**

*Data given:*

Shape of section of open channel: Triangular

Slope of each side of the channel section =  $45^\circ$  to the vertical.

Topic: Flow in Open Channels (Uniform Flow)

Discharge,  $Q = 0.04 \text{ m}^3/\text{s}$

Depth of flow at the centre of channel section,  $y = 225 \text{ mm} = 0.225 \text{ m}$

Bed slope of the channel,  $S = ?$

Chezy's  $C = 50$

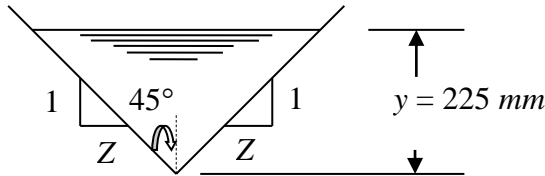

$$\tan 45^\circ = \frac{Z}{1}$$
$$\Rightarrow Z = \tan 45^\circ = 1$$

Wetted area of channel section,  $A = Zy^2 = 1 \times (0.225)^2 = 0.050625 \text{ m}^2$

As per the continuity principle, we have,

$$Q = AV$$

where  $V$  = mean velocity of flow in channel

$$\text{Therefore, } V = \frac{Q}{A} = \frac{0.04}{0.050625} = 0.79 \text{ m/s}$$

Wetted perimeter,  $P = 2y\sqrt{Z^2 + 1} = 2(0.225)\sqrt{1^2 + 1} = 0.6364 \text{ m}$

Hydraulic radius,  $R = \frac{A}{P} = \frac{0.050625}{0.6364} = 0.07955 \text{ m}$

Chezy's formula:  $V = C\sqrt{RS}$

$$\Rightarrow 0.79 = 50 \times \sqrt{(0.07955)S}$$

$$\Rightarrow S = \frac{(0.79)^2}{(50)^2 \times 0.07955} = 0.00314 = \frac{1}{319}$$

**Problem:** A rectangular channel is  $2.5 \text{ m}$  wide and has a uniform bed slope of 1 in 500. If the depth of flow is constant at  $1.7 \text{ m}$  calculate (a) the hydraulic mean depth, (b) the velocity of flow, (c) the volume rate of flow. Assume that the value of the coefficient  $C$  in Chezy's formula is 50.

Solution.

Topic: Flow in Open Channels (Uniform Flow)

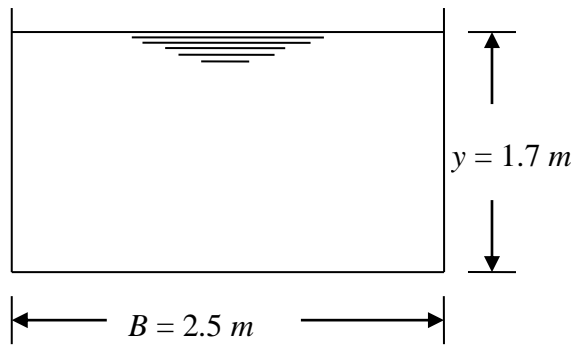

Data:

Bottom width of channel,  $B = 2.5 \text{ m}$   
 Depth of flow,  $y = 1.7 \text{ m}$   
 Bed slope,  $S_o = 1 \text{ in } 500$   
 Chezy's constant,  $C = 50$

(a) Hydraulic mean depth,  $R = \frac{A}{P}$

where,  $A = \text{wetted area} = By = 2.5 \times 1.7 = 4.25 \text{ m}^2$

$P = \text{wetted perimeter} = B + 2y = 2.5 + (2 \times 1.7) = 2.5 + 3.4 = 5.9 \text{ m}$

$$R = \frac{A}{P} = \frac{4.25}{5.9} = 0.72 \text{ m}$$

(b) Velocity of flow,  $V = C\sqrt{RS} = 50 \sqrt{(0.72)\left(\frac{1}{500}\right)} = 1.897 \text{ ms}^{-1}$

(Note: For uniform steady flow, energy gradient,  $S = \text{bed slope, } S_o = 1 / 500$ )

© Volume rate of flow,  $Q = AV = 4.25 \times 1.897 = 8.064 \text{ m}^3/\text{s}$

**Problem:** An open channel has a vee-shaped cross section with sides inclined at an angle of  $60^\circ$  to the vertical. If the rate of flow is  $80 \text{ dm}^3 \text{ s}^{-1}$  when the depth at the centre is  $0.25 \text{ m}$ , what must be the slope of the channel assuming  $C = 45$ .

**Solution.**

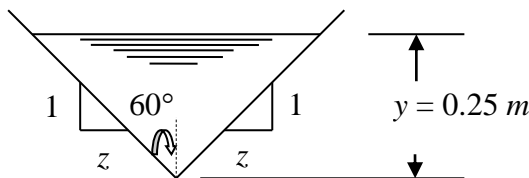

$$\tan 60^\circ = \frac{z}{1}$$

$$\Rightarrow z = \tan 60^\circ = 1.734$$

$$Q = 80 \text{ dm}^3 \text{ s}^{-1} = 80 \times (10^{-1})^3 = 80 \times 10^{-3} \text{ m}^3 \text{ s}^{-1}$$

(Note:  $1 \text{ dm} = 10 \text{ cm} = 0.1 \text{ m} = 10^{-1} \text{ m}$ )

Wetted area of channel section,  $A = Zy^2 = 1.734 \times (0.25)^2 = 0.108 \text{ m}^2$

As per the continuity principle, we have,

Topic: Flow in Open Channels (Uniform Flow)

$$Q = AV$$

where  $V$  = mean velocity of flow in channel

$$\text{Therefore, } V = \frac{Q}{A} = \frac{0.08}{0.108} = 0.738 \text{ m/s}$$

$$\text{Wetted perimeter, } P = 2y\sqrt{Z^2 + 1} = 2(0.25)\sqrt{(1.734)^2 + 1} = 1.000 \text{ m}$$

$$\text{Hydraulic radius, } R = \frac{A}{P} = \frac{0.108}{1.000} = 0.108 \text{ m}$$

$$\text{Chezy's formula: } V = C\sqrt{RS}$$

$$\Rightarrow 0.738 = 45 \times \sqrt{(0.108)S}$$

$$\Rightarrow S = \frac{(0.738)^2}{(45)^2 \times 0.108} = 0.00249 = \frac{1}{401}$$

**Problem:** A channel 5 m wide at the top and 2 m deep has sides sloping 2 vertically in 1 horizontally. The slope of the channel is 1 in 1000. Find the volume rate of flow when the depth of water is constant at 1 m. Take  $C$  as 53.

What would be the depth of water if the flow rate were to be doubled?

**Solution.**

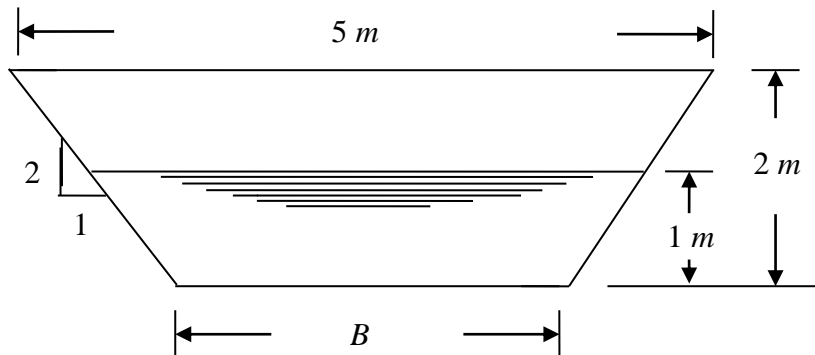

Data:

Top width of channel,  $T_w = 5 \text{ m}$

Depth of channel,  $d = 2 \text{ m}$

Let Bottom width of channel be  $B$

Side slope = 2 vertical : 1 horizontal = 1 vertical : 0.5 horizontal = 1 : z

Bottom slope of the channel,  $S_o = 1 \text{ in } 1000$

Depth of flow in the channel,  $y = 1 \text{ m}$

$$T_w = B + 2zd$$

$$\Rightarrow 5 = B + 2 \times 0.5 \times 2 = B + 2$$

$$\Rightarrow B = 5 - 2 = 3 \text{ m}$$

For uniform steady flow,

Topic: Flow in Open Channels (Uniform Flow)

Energy gradient,  $S =$  Bed slope of channel,  $S_o = \frac{1}{1000} = 0.001$

Mean velocity of flow,  $V = C\sqrt{RS}$

Wetted area,  $A = (B + zy)y = [3 + (0.5)(1)](1) = 3.5 \text{ m}^2$

Wetted perimeter,  $P = B + 2y\sqrt{z^2 + 1} = 3 + 2(1)\sqrt{(0.5)^2 + 1} = 5.236 \text{ m}$

Hydraulic radius,  $R = \frac{A}{P} = \frac{3.5}{5.236} = 0.668 \text{ m}$

$V = 53\sqrt{(0.668)(0.001)} = 1.37 \text{ ms}^{-1}$

$Q = AV = 3.5 \times 1.37 = 4.8 \text{ m}^3 \text{ s}^{-1}$

Depth of flow when the flow is doubled = ?

Now,  $Q = 2(4.8) = 9.6 \text{ m}^3 \text{ s}^{-1}$

$Q = 9.6 = AV$

Wetted area  $A = (B + zy)y = [3 + (0.5)y]y = 3y + 0.5y^2$

$V = C\sqrt{RS}$

Wetted perimeter,  $P = B + 2y\sqrt{z^2 + 1} = 3 + 2y\sqrt{(0.5)^2 + 1} = 3 + 2.236y$

$R = \frac{A}{P} = \frac{3y + 0.5y^2}{3 + 2.236y}$

Hence,  $Q = 9.6 = (3y + 0.5y^2)(53)\sqrt{\left(\frac{3y + 0.5y^2}{3 + 2.236y}\right)(0.001)}$

Solving by trial and error,  $y = 1.6 \text{ m}$

**Problem:** Water is conveyed in a channel of semi-circular cross-section with a slope of 1 in 2500. The Chezy coefficient  $C$  has a value of 56. If the radius of the channel is 0.55 m, what will be the volume flowing per second when the depth of flow is equal to the radius?

If the channel had been rectangular in form with the same width of 1.1 m and depth of flow of 0.55 m, what would be the discharge for the same slope and value of  $C$ ?

**Solution.**

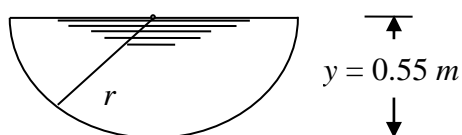

Data:

Radius of semicircular channel,  $r = 0.55 \text{ m}$

Depth of flow,  $y = r = 0.55 \text{ m}$

Bed slope of channel,  $S_o = 1$  in 2500

Topic: Flow in Open Channels (Uniform Flow)

Chezy coefficient,  $C = 56$

$$Q = AV$$

$$\text{Where } A = \text{wetted area} = \frac{\pi r^2}{2} = \frac{\pi(0.55)^2}{2} = 0.4754 \text{ m}^2$$

$$V = \text{mean velocity of flow} = C\sqrt{RS}$$

$$R = \text{hydraulic mean depth} = \frac{A}{P}$$

$$P = \text{wetted perimeter} = \pi r = \pi(0.55) = 1.729 \text{ m}$$

$$R = \frac{0.4754}{1.729} = 0.275 \text{ m}$$

$$\text{Hence, } Q = AC\sqrt{RS} = 0.4754 \times 56 \times \sqrt{(0.275)\left(\frac{1}{2500}\right)} = 0.279 \text{ m}^3 \text{ s}^{-1}$$

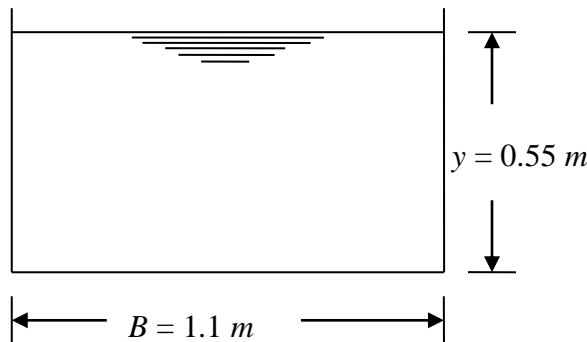

Data:

Bottom width of channel,  $B = 1.1 \text{ m}$

Depth of flow,  $y = 0.55 \text{ m}$

Bed slope,  $S_o = 1 \text{ in } 2500$

Chezy's constant,  $C = 56$

$$\text{Wetted area, } A = By = 1.1 \times 0.55 = 0.605 \text{ m}^2$$

$$\text{Wetted perimeter, } P = B + 2y = 1.1 + (2 \times 0.55) = 1.1 + 1.1 = 2.2 \text{ m}$$

$$\text{Hydraulic radius, } R = \frac{A}{P} = \frac{0.605}{2.2} = 0.275 \text{ m}$$

$$\text{Mean velocity of flow, } V = C\sqrt{RS} = 56 \sqrt{(0.275)\left(\frac{1}{2500}\right)} = 0.587 \text{ m s}^{-1}$$

$$\text{Volume rate of flow, } Q = AV = 0.605 \times 0.587 = 0.355 \text{ m}^3 \text{ s}^{-1}$$

**Problem:** An open channel has a cross-section in the form of trapezium as shown in Figure below. Assuming that the roughness coefficient  $n$  is 0.025, the bed slope is 1 in 1800 and the depth of flow is 1.2 m, find the volume rate of flow  $Q$  using (a) Chezy's formula with  $C$  determined from the Kutter's formula, and (b) the Manning's formula.



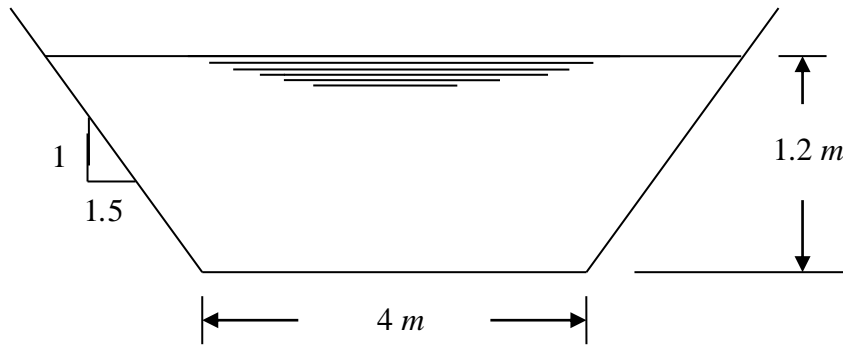

**Solution.**

*Data:*

Bottom width of channel,  $B = 4 \text{ m}$

Side slope = 1 vertical: z horizontal = 1 : 1.5

Depth of flow,  $y = 1.2 \text{ m}$

Manning's roughness coefficient,  $n = 0.025$

Bed slope,  $S_o = 1 / 1800$

Required: Volume flow rate,  $Q$

(a) Using Chezy's formula:

$$\text{Wetted area, } A = (B + zy)y = [4 + (1.5)(1.2)](1.2) = 6.96 \text{ m}^2$$

$$\text{Wetted perimeter, } P = B + 2y\sqrt{z^2 + 1} = 4 + 2(1.2)\sqrt{(1.5)^2 + 1} = 8.327 \text{ m}$$

$$\text{Hydraulic radius, } R = \frac{A}{P} = \frac{6.96}{8.327} = 0.836 \text{ m}$$

For uniform steady flow, energy gradient,  $S =$  bed slope,  $S_o = \frac{1}{1800}$

Chezy's  $C$  is computed from Kutter's formula as:

$$C = \frac{23 + \frac{0.00155}{S} + \frac{1}{n}}{1 + \left(23 + \frac{0.00155}{S}\right) \frac{n}{\sqrt{R}}} = \frac{23 + \frac{0.00155}{\left(\frac{1}{1800}\right)} + \frac{1}{0.025}}{1 + \left(23 + \frac{0.00155}{\left(\frac{1}{1800}\right)}\right) \frac{0.025}{\sqrt{0.836}}} = 38.6$$

Mean velocity of flow,  $V = C\sqrt{RS}$

$$Q = AV = AC\sqrt{RS} = 6.96 \times 38.6 \sqrt{(0.836)\left(\frac{1}{1800}\right)} = 5.79 \text{ m}^3\text{s}^{-1}$$

(b) Using Manning's formula:

Manning's formula for mean velocity of flow is given by

$$V = \frac{1}{n} R^{2/3} S^{1/2}$$

$$Q = AV = A \frac{1}{n} R^{2/3} S^{1/2} = (6.96) \left( \frac{1}{0.025} \right) (0.836)^{2/3} \left( \frac{1}{1800} \right)^{1/2} \\ = 5.82 \text{ m}^3 \text{ s}^{-1}$$

**Problem:** An earth channel is trapezoidal in cross-section with a bottom width of 1.8 m and side slopes of 1 vertical to 2 horizontal. Taking the friction coefficient in the Bazin formula as 1.3 and the slope of the bed as 0.57 m per kilometre, find the discharge in cubic metres per second when the depth of flow is 1.5 m.

Solution.

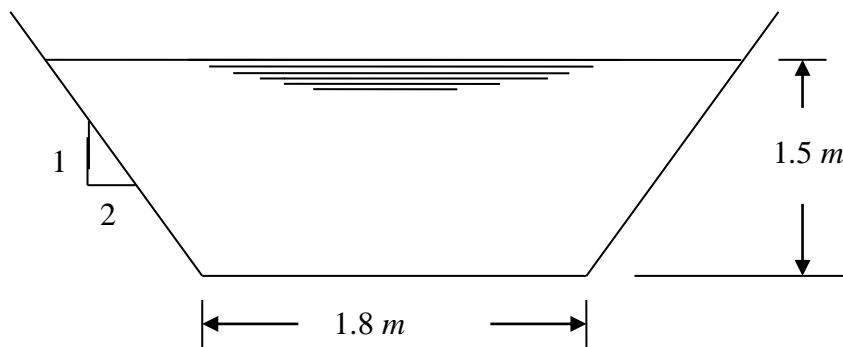

Data:

Bottom width,  $B = 1.8 \text{ m}$

Side slope = 1 vertical : 2 horizontal = 1 vertical : z horizontal

Bazin's friction coefficient,  $K = 1.3$

Bed slope,  $S_o = 0.57 \text{ m per km} = 0.57 \text{ m} / 1000 \text{ m} = 0.00057$

Depth of flow,  $y = 1.5 \text{ m}$

Required:

Discharge,  $Q = ?$

$$\text{Wetted area, } A = (B + zy)y = [1.8 + (2)(1.5)](1.5) = 7.2 \text{ m}^2$$

$$\text{Wetted perimeter, } P = B + 2y\sqrt{z^2 + 1} = 1.8 + 2(1.5)\sqrt{(2)^2 + 1} = 8.508 \text{ m}$$

$$\text{Hydraulic radius, } R = \frac{A}{P} = \frac{7.2}{8.508} = 0.846 \text{ m}$$

Topic: Flow in Open Channels (Uniform Flow)

Bazin's formula for evaluating Chezy's constant  $C$ :

$$C = \frac{86.9}{1 + \frac{K}{\sqrt{R}}} = \frac{86.9}{1 + \frac{1.3}{\sqrt{0.846}}} = 36$$

Mean velocity of flow,  $V = C\sqrt{RS} = 36 \sqrt{(0.846)(0.00057)} = 0.791 \text{ m s}^{-1}$

Discharge,  $Q = AV = 7.2 \times 0.791 = 5.69 \text{ m}^3\text{s}^{-1}$

**Problem:** An open channel is to be constructed of trapezoidal section and with side slopes 1 vertical to 1.5 horizontal. Find the proportions, that is, the relation between bottom width and depth of flow) for minimum excavation (that is, best hydraulic section).

If the flow is to be  $2.7 \text{ m}^3/\text{s}$ , calculate the bottom width and the depth of flow assuming Chezy's  $C$  as 44.5 and the bed slope as 1 in 4000.

**Solution.**

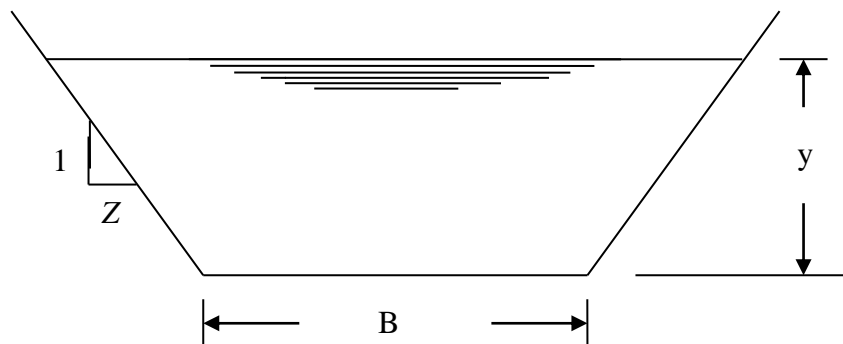

Side slope of channel section = 1 vertical : z horizontal = 1 : 1.5

Let the bottom width of channel section be  $B$  and the depth of flow be  $y$ .

$Q = 2.7 \text{ m}^3/\text{s}$

$C = 44.5$

Bed slope  $S = 1 \text{ in } 4000 = \frac{1}{4000} = 0.00025$

$B = ?$

$y = ?$

*Required:*

To find the relation between bottom width  $B$  and the depth of flow  $y$  for most economical section of channel

Topic: Flow in Open Channels (Uniform Flow)

For most economical trapezoidal section, we have,

$$\frac{B + 2zy}{2} = y\sqrt{1 + z^2}$$

$$\frac{B + 2(1.5)y}{2} = y\sqrt{1 + (1.5)^2}$$

$$\Rightarrow B + 3y = 2y\sqrt{1 + 2.25} = 2y\sqrt{3.25} = 3.6056y$$

$$\Rightarrow B = 3.6056y - 3y = 0.6056y$$

$$\Rightarrow \frac{B}{y} = 0.6056$$

$$\text{Wetted area, } A = (B + zy)y = (0.6056y + 1.5y)y = 2.1056y^2$$

$$\begin{aligned}\text{Wetted perimeter, } P &= B + 2y\sqrt{z^2 + 1} = 0.6056y + 2y\sqrt{(1.5)^2 + 1} \\ &= 0.6056y + 3.6056y = 4.2112y\end{aligned}$$

$$\text{Hydraulic radius, } R = \frac{A}{P} = \frac{2.1056y^2}{4.2112y} = 0.5121y$$

As per continuity principle, we have,

$$Q = A.V$$

$$\text{Hence, } V = \frac{Q}{A}$$

$$\Rightarrow V = \frac{2.7}{2.1056y^2} = \frac{1.2823}{y^2}$$

As per Chezy's formula, we have,

$$V = C\sqrt{RS}$$

$$\Rightarrow \frac{1.2823}{y^2} = 44.5\sqrt{(0.5121y)(0.00025)}$$

$$\Rightarrow \frac{1.64428}{y^4} = (1980.25)(0.5121y)(0.00025)$$

$$\Rightarrow 1.64428 = 0.253522 y^5$$

$$\Rightarrow y^5 = \frac{1.64428}{0.253522} = 6.485762$$

$$\Rightarrow y = 1.453 \text{ m}$$

$$\text{Hence, bottom width, } B = 0.6056 y = 0.6056 \times 1.453 = 0.880 \text{ m}$$

**Problem:** A trapezoidal channel has side slopes of 3 horizontal to 4 vertical and the slope of its bed is 1 in 2000. Determine the optimum dimensions of the channel if it is to carry water at  $0.5 \text{ m}^3 \text{ s}^{-1}$ . Use the Chezy's formula, assuming that  $C = 80 \text{ m}^{1/2} \text{ s}^{-1}$ .

**Solution.**

Topic: Flow in Open Channels (Uniform Flow)

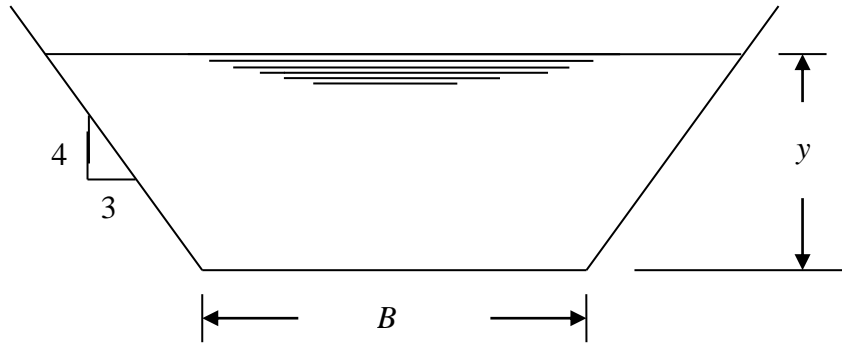

Data:

Side slope of channel = 3 horizontal : 4 vertical = z horizontal : 1 vertical  
= 0.75 : 1

Bottom slope,  $S_o = 1$  in 2000

Discharge,  $Q = 0.5 \text{ m}^3 \text{ s}^{-1}$

Chezy's constant  $C = 80 \text{ m}^{1/2} \text{ s}^{-1}$

Required: To find the optimum dimensions of the channel.

For most economical trapezoidal section, we have,

$$\frac{B + 2zy}{2} = y\sqrt{1 + z^2}$$

$$\frac{B + 2(0.75)y}{2} = y\sqrt{1 + (0.75)^2}$$

$$\Rightarrow B + 1.5y = 2y\sqrt{1 + 0.5625} = 2y\sqrt{1.5625} = 2.5y$$

$$\Rightarrow B = 2.5y - 1.5y = y$$

$$\Rightarrow \frac{B}{y} = 1$$

Wetted area,  $A = (B + zy)y = (y + 0.75y)y = 1.75y^2$

Wetted perimeter,  $P = B + 2y\sqrt{z^2 + 1} = y + 2y\sqrt{(0.75)^2 + 1}$   
 $= y + 2.5y = 3.5y$

Hydraulic radius,  $R = \frac{A}{P} = \frac{1.75y^2}{3.5y} = 0.5y$

As per continuity principle, we have,

$$Q = A.V$$

Hence,  $V = \frac{Q}{A}$

$$\Rightarrow V = \frac{0.5}{1.75y^2} = \frac{0.285714}{y^2}$$

As per Chezy's formula, we have,

$$V = C\sqrt{RS}$$

Topic: Flow in Open Channels (Uniform Flow)

$$\begin{aligned}\Rightarrow \frac{0.285714}{y^2} &= 80 \sqrt{(0.5y) \left( \frac{1}{2000} \right)} \\ \Rightarrow \frac{0.081633}{y^4} &= (6400)(0.5y)(0.0005) \\ \Rightarrow 0.081633 &= 1.6 y^5 \\ \Rightarrow y^5 &= \frac{0.081633}{1.6} = 0.051 \\ \Rightarrow y &= 0.552 \text{ m}\end{aligned}$$

Hence, bottom width,  $B = y = 0.552 \text{ m}$

**Problem:** It is required to excavate a canal of rectangular section out of rock to bring  $15 \text{ m}^3$  of water per second from a distance of  $6.4 \text{ km}$  with a velocity of  $2.25 \text{ m/s}$ . Determine the most suitable section for the canal and its gradient. Take Manning's  $n = 0.02$ .

**Solution.**

Discharge,  $Q = 15 \text{ m}^3/\text{s}$

Velocity of flow in channel,  $V = 2.25 \text{ m/s}$

Manning's  $n = 0.02$

As per continuity principle, we have,

$$Q = AV$$

where  $A =$  wetted area

$$A = \frac{Q}{V} = \frac{15}{2.25} = 6.667 \text{ m}^2$$

For a rectangular channel section, we have,  $A = By$

where  $B =$  bottom width

$y =$  depth of flow

For most economical rectangular channel section, we have,

$$y = \frac{B}{2} \quad (\text{or}) \quad B = 2y$$

Hence,  $A = 6.667 = (2y)y = 2y^2$

$$\Rightarrow y = \sqrt{\frac{6.667}{2}} = 1.826 \text{ m}$$

$$B = 2y = 2 \times 1.826 = 3.651 \text{ m}$$

$$\begin{aligned}\text{Wetted perimeter, } P &= B + 2y = 3.651 + 2(1.826) = 3.651 + 3.651 \\ &= 7.302 \text{ m}\end{aligned}$$

$$\text{Hydraulic radius, } R = \frac{A}{P} = \frac{6.667}{7.302} = 0.913 \text{ m}$$

As per Manning's formula, we have,

$$V = \frac{1}{n} R^{2/3} S^{1/2}$$

Topic: Flow in Open Channels (Uniform Flow)

$$\Rightarrow S^{1/2} = \frac{2.25 \times 0.02}{(0.913)^{2/3}} = \frac{0.045}{0.941} = 0.047815$$

$$\Rightarrow S = 0.00229$$

**Problem:** The water supply for a turbine passes through a conduit which for convenience has its cross-section in the form of a square with one diagonal vertical. If the conduit is required to convey  $8.5 \times 10^{-3} \text{ m}^3 \text{ s}^{-1}$  under conditions of maximum discharge at atmospheric pressure when the slope of the bed is 1 in 4900, determine its size assuming that the velocity of flow is given by  $V = 80R^{2/3}S^{1/2}$ .

**Solution.**

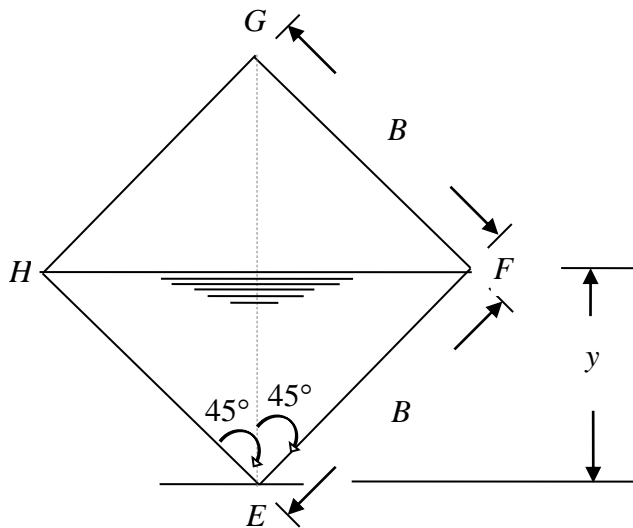

For most economical square section (that is, for square section to carry the maximum discharge), we have,

Depth of flow = half the bottom width  
i.e.,  $y = B/2$

When the same square section is placed with one of its diagonals vertical as shown in Figure, for maximum discharge, the depth of flow  $y$  becomes equal to half the height of the vertical diagonal and the free surface of flow coincides with the other diagonal that is horizontal.

$$\text{Length of diagonal} = \sqrt{2}B$$

$$\text{Depth of flow, } y = \frac{\sqrt{2}B}{2}$$

$$\text{Hydraulic radius, } R = \frac{y}{2} = \frac{\left(\frac{\sqrt{2}B}{2}\right)}{2} = \frac{\sqrt{2}B}{4}$$

$$\text{Wetted area, } A = \frac{1}{2}(EF)(EH) = \frac{1}{2} \times B \times B = \frac{B^2}{2}$$

$$V = 80R^{2/3}S^{1/2}$$

Topic: Flow in Open Channels (Uniform Flow)

$$\begin{aligned} &= 80 \left( \frac{\sqrt{2B}}{4} \right)^{2/3} \left( \frac{1}{4900} \right)^{1/2} \\ Q &= AV = \left( \frac{B^2}{2} \right) 80 \left( \frac{\sqrt{2B}}{4} \right)^{2/3} \left( \frac{1}{4900} \right)^{1/2} \\ \Rightarrow 8.5 \times 10^{-3} &= \left( \frac{B^2}{2} \right) 80 \left( \frac{\sqrt{2B}}{4} \right)^{2/3} \left( \frac{1}{4900} \right)^{1/2} = 0.285714 B^{8/3} \\ \Rightarrow B^{8/3} &= \frac{0.0085}{0.285714} = 0.02975 \\ \Rightarrow B &= (0.02975)^{3/8} = 0.268 \text{ m} \end{aligned}$$

**Problem:** Determine the most efficient section of a trapezoidal channel with side slopes 1 vertical to 2 horizontal. The channel carries a discharge of  $11.25 \text{ m}^3/\text{s}$  with a velocity of  $0.75 \text{ m/s}$ . What should be the bed slope of the channel? Take Manning's  $n = 0.025$ .

**Solution.**

Side slope of channel section = 1 vertical : z horizontal = 1 : 2

Discharge,  $Q = 11.25 \text{ m}^3/\text{s}$

Velocity of flow in channel,  $V = 0.75 \text{ m/s}$

Manning's  $n = 0.025$

The channel section is considered to be most economical.

Bed slope of channel,  $S = ?$

For most economical trapezoidal channel section, we have,

$$\frac{B + 2zy}{2} = y\sqrt{1 + z^2}$$

$$\frac{B + 2(2)y}{2} = y\sqrt{1 + 2^2}$$

$$\Rightarrow B + 4y = 2y\sqrt{1 + 4} = 2y\sqrt{5} = 4.472y$$

$$\Rightarrow B = 4.472y - 4y = 0.472y$$

$$\Rightarrow \frac{B}{y} = 0.472$$

As per continuity principle, we have,

$$Q = AV$$

where  $A$  = wetted area

$$A = \frac{Q}{V} = \frac{11.25}{0.75} = 15 \text{ m}^2 = (B + zy)y = (0.472y + 2y)y = 2.472y^2$$



Topic: Flow in Open Channels (Uniform Flow)

$$\Rightarrow y^2 = \frac{15}{2.472}$$

$$\Rightarrow y = 2.463 \text{ m}$$

$$\text{Hence, } B = 0.472 y = 0.472 \times 2.463 = 1.163 \text{ m}$$

$$\begin{aligned} \text{Wetted perimeter, } P &= B + 2y\sqrt{z^2 + 1} = 0.472y + 2y\sqrt{2^2 + 1} \\ &= 0.472 y + 4.472 y = 4.944 y \\ &= 4.944 \times 2.463 \\ &= 12.177 \text{ m} \end{aligned}$$

$$\text{Hydraulic radius, } R = \frac{A}{P} = \frac{15}{12.177} = 1.232 \text{ m}$$

As per Manning's formula, we have,

$$V = \frac{1}{n} R^{2/3} S^{1/2}$$

$$\Rightarrow 0.75 = \frac{1}{0.025} (1.232)^{2/3} S^{1/2}$$

$$\Rightarrow S^{1/2} = \frac{0.75 \times 0.025}{(1.232)^{2/3}} = 0.0163$$

$$\Rightarrow S = 0.000266$$

**Problem:** A canal is to have a trapezoidal section with one side vertical and the other side sloping at  $45^\circ$ . It has to carry a discharge of  $30 \text{ m}^3/\text{s}$  with an average velocity of  $1 \text{ m/s}$ . Compute the dimensions of the section which will require the minimum lining.

**Solution.**

Discharge,  $Q = 30 \text{ m}^3/\text{s}$

Average velocity of flow,  $V = 1 \text{ m/s}$

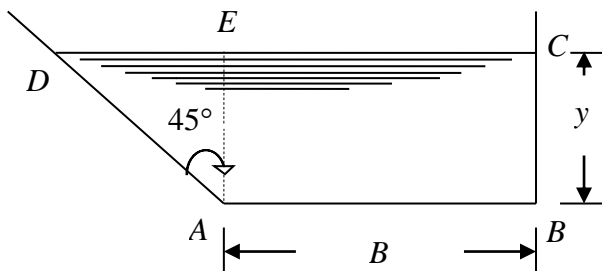

The trapezoidal section  $ABCD$  is made up of a rectangular portion  $ABCE$  of dimensions  $(B \times y)$  and a triangular portion  $AED$  right – angled at  $E$ .

$$\text{From triangle } AED, \tan 45^\circ = \frac{ED}{AE} = \frac{ED}{y} = 1$$

Hence,  $ED = y$

Topic: Flow in Open Channels (Uniform Flow)

$$\text{Hence, area of triangular portion} = \frac{1}{2} \times ED \times AE = \frac{1}{2} \times y \times y = \frac{y^2}{2}$$

$$\text{Area of rectangular portion} = By$$

$$\text{Hence, area of trapezoidal section, } A = By + \frac{y^2}{2}$$

$$By = A - \frac{y^2}{2}$$

$$B = \frac{A}{y} - \frac{y}{2}$$

$$\begin{aligned} \text{Wetted perimeter, } P = DA + AB + BC &= \sqrt{(AE)^2 + (ED)^2} + B + y \\ &= \sqrt{y^2 + y^2} + B + y \\ &= \sqrt{2y^2} + B + y \\ &= \sqrt{2}y + B + y \\ &= 2.414 y + B \end{aligned}$$

Putting  $B = \frac{A}{y} - \frac{y}{2}$  in  $P = 2.414 y + B$ , we have,

$$P = 2.414 y + \frac{A}{y} - \frac{y}{2}$$

Assuming area  $A$  to be constant, the above equation can be differentiated with respect to  $y$  and equated to zero for obtaining the condition for minimum  $P$ .

$$\text{Hence, } \frac{dP}{dy} = 2.414 - \frac{A}{y^2} - \frac{1}{2} = 1.914 - \frac{A}{y^2} = 0$$

Putting  $A = By + \frac{y^2}{2}$ , we have,

$$1.914 - \frac{By + \frac{y^2}{2}}{y^2} = 0$$

$$\Rightarrow 1.914 y^2 - By - \frac{y^2}{2} = 0$$

$$\Rightarrow 1.414 y^2 - By = 0$$

$$\Rightarrow By = 1.414 y^2$$

$$\Rightarrow B = 1.414 y = \sqrt{2}y$$

This is the condition for most economical trapezoidal section of channel defined in the problem.

From continuity principle, we have,

$$\text{Wetted area of flow, } A = \frac{Q}{V} = \frac{30}{1} = 30 \text{ m}^2$$

$$\text{We have, } A = By + \frac{y^2}{2}$$

Putting  $B = 1.414 y$ , we have,

$$A = 30 \text{ m}^2 = (1.414 y) y + \frac{y^2}{2}$$

$$\Rightarrow 1.414 y^2 + \frac{y^2}{2} = 30$$

$$\Rightarrow 1.914 y^2 = 30$$

$$\Rightarrow y^2 = \frac{30}{1.914} = 15.674$$

$$\Rightarrow y = 3.959 \text{ m}$$

$$\text{Hence, } B = 1.414 y = 1.414 \times 3.959 = 5.598 \text{ m}$$

**Problem:** An open channel laid at a constant slope is required to carry a maximum discharge of  $5 \text{ m}^3/\text{s}$  and a minimum discharge of  $1 \text{ m}^3/\text{s}$  at a constant velocity of  $1 \text{ m/s}$  at all depths of flow. Compute the top width at the free surface and the depths of flow corresponding to minimum and maximum discharges. For minimum discharge, a rectangular channel section of the most economical type may be designed.

**Solution.**

Maximum discharge,  $Q_{max} = 5 \text{ m}^3/\text{s}$

Minimum discharge,  $Q_{min} = 1 \text{ m}^3/\text{s}$

Constant velocity of flow,  $V = 1 \text{ m/s}$

For minimum discharge, a rectangular section that is most economical is to be designed.

**Case (i) Discharge is minimum**

$$Q_{min} = 1 \text{ m}^3/\text{s}$$

As per continuity principle, we have,

$$Q_{min} = AV$$

where  $A$  = wetted area of rectangular channel section when the discharge is minimum

$$A = \frac{Q_{min}}{V} = \frac{1}{1} = 1 \text{ m}^2$$

For rectangular channel section,  $A = By$

where  $B$  = bottom width of channel section

$y$  = depth of flow corresponding to minimum discharge

Further, for most economical rectangular channel section, we have,

Topic: Flow in Open Channels (Uniform Flow)

$$y = \frac{B}{2}$$

Putting  $y = \frac{B}{2}$  in  $A = By$ , we have,

$$1 = B \times \frac{B}{2} = \frac{B^2}{2}$$

$$\Rightarrow B^2 = 2$$

$$\Rightarrow B = 1.414 \text{ m}$$

Hence,  $y = 1.414 / 2 = 0.707 \text{ m}$

$$\begin{aligned} \text{Wetted perimeter of most economical rectangular section, } P &= B + 2y \\ &= 1.414 + 2 \times 0.707 \\ &= 2.828 \text{ m} \end{aligned}$$

Hydraulic radius,  $R = A/P = 1 / 2.828 = 0.3536 \text{ m}$

**Note:** the velocity of flow is constant at all depths of flow if the hydraulic radius is constant at all depths of flow.

When the discharge is maximum equal to  $5 \text{ m}^3/\text{s}$ ,

$$A = Q / V = 5 / 1 = 5 \text{ m}^2$$

$$R = 0.375 \text{ m} = A / P = 5 / P$$

$\Rightarrow P = 5 / 0.375 = 13.333 \text{ m} =$  width of bottom rectangular section + 2 (depth of rectangular section) + 2 (length of each side of the constant velocity section)

i.e.,  $13.333 = 1.414 + 2(0.707) + 2(\text{length of each side of the constant velocity section})$

Length of each side of the constant velocity section

$$\begin{aligned} &= [13.333 - 1.414 - 2(0.707)] / 2 \\ &= 5.2525 \text{ m} \end{aligned}$$

The cross-section of a channel with constant velocity at all depths of flow is defined by the equation

$$y = R \log_e \left( x + \sqrt{x^2 - R^2} \right) + C$$

$$\text{For } x = \frac{1.414}{2} = 0.707 \text{ m}; y = 0$$

$$\text{Hence, } C = - R \log_e \left( x + \sqrt{x^2 - R^2} \right) = - R \log_e \left( 0.707 + \sqrt{(0.707)^2 - R^2} \right)$$

$$\text{Thus, } y = R \log_e \left( x + \sqrt{x^2 - R^2} \right) - R \log_e \left( 0.707 + \sqrt{(0.707)^2 - R^2} \right)$$

$$= R \log_e \left[ \frac{\left( x + \sqrt{x^2 - R^2} \right)}{\left( 0.707 + \sqrt{(0.707)^2 - R^2} \right)} \right]$$

**Solution incomplete**

**Problem:** A trapezoidal channel with side slopes of 2 horizontal to 1 vertical has to carry a discharge of  $20 \text{ m}^3/\text{s}$ . if the bottom width is  $4 \text{ m}$ , calculate the bottom slope required to maintain a uniform flow at a depth of  $1.5 \text{ m}$ . Take Manning's  $n = 0.015$ .

What would be the normal depth of flow for the above channel to carry a discharge of  $27 \text{ m}^3/\text{s}$ ?

**Solution.**

$$\text{Wetted area of channel section, } A = (B + zy) y = [4 + (2) (1.5)] (1.5) \\ = 10.5 \text{ m}^2$$

$$\text{Wetted Perimeter, } P = B + 2y\sqrt{z^2 + 1} = 4 + 2(1.5) \sqrt{2^2 + 1} = 10.708 \text{ m}$$

$$\text{Hydraulic radius, } R = A/P = 10.5 / 10.708 = 0.981 \text{ m}$$

Manning's formula:

$$V = \frac{1}{n} R^{2/3} S^{1/2}$$

As  $Q = AV$ , we have,

$$Q = A \frac{1}{n} R^{2/3} S^{1/2} = \frac{1}{n} AR^{2/3} S^{1/2}$$

$$\Rightarrow 20 = \frac{1}{0.015} (10.5)(0.981)^{2/3} S^{1/2}$$

$$\Rightarrow S^{1/2} = \frac{(20)(0.015)}{(10.5)(0.981)^{2/3}} = 0.0289$$

$$\Rightarrow S = 0.000837 = 1 \text{ in } 1194 \text{ (i.e., 1 vertical to 1194 horizontal)}$$

Let  $y$  be the normal depth of flow

$$Q = 27 \text{ m}^3/\text{s}$$

$$A = (B + zy) y = (4 + 2y) y$$

$$P = B + 2y\sqrt{z^2 + 1} = 4 + 2y \sqrt{2^2 + 1} = 4 + 2y \sqrt{5}$$

$$R = A / P = \frac{(4 + 2y)y}{(4 + 2y\sqrt{5})}$$

$$Q = AV = A \frac{1}{n} R^{2/3} S^{1/2}$$

$$\Rightarrow 27 = [(4 + 2y) y] \frac{1}{n} \left[ \frac{(4 + 2y)y}{(4 + 2y\sqrt{5})} \right]^{2/3} (0.000837)^{1/2}$$

$$\Rightarrow 27 = \left( \frac{1}{0.015} \right) \frac{[(4 + 2y)y]^{5/3}}{[(4 + 2y\sqrt{5})]^{2/3}} (0.000837)^{1/2}$$

*Topic:* Flow in Open Channels (Uniform Flow)

Solving for  $y$  by trial and error, we have,  $y = 1.745 \text{ m}$